

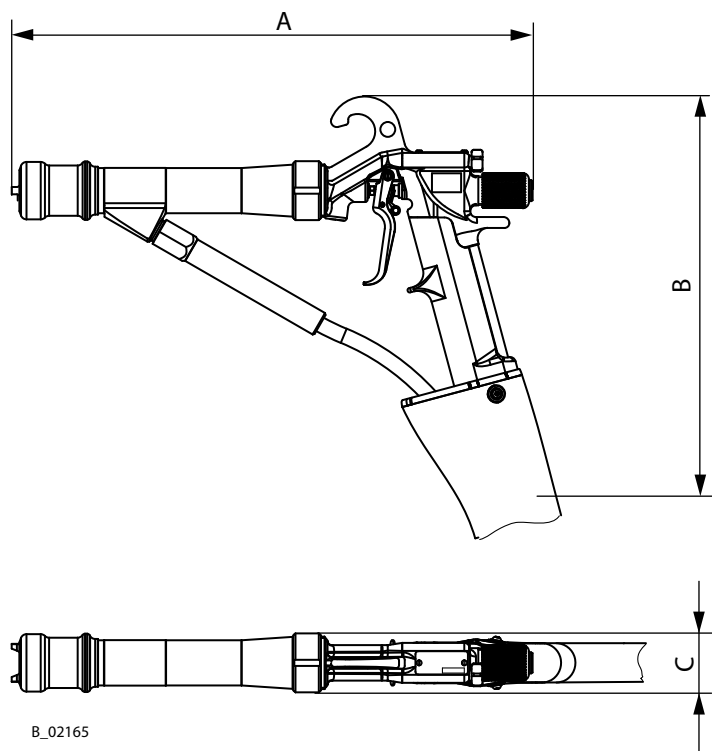

4.3.2 SPRAY GUN GM 2900EACW

Description	Data		
Air pressure maxi.	0.8 MPa	8 bar	116 psi
Material pressure maxi.	25 MPa	250 bar	3626 psi
Paint connection	M16x1.5		
Air connection	R 1/4"		
Hose set lengths	7.5 m	24.6 ft	
	10 m	32.8 ft	
	15 m	49.2 ft	
	20 m	65.6 ft	
Weight (without cables)	0.8 kg	1.76 lb	
Working temperature range	5-40°C	41-104°F	
Maxi. material temperature	60°C	140°F	
Quantity of fluid	according to nozzle sizes (See nozzle list on accessories)		
Sound power at 0.2 MPa; 2 bar; 29 psi air pressure (depending on nozzle used)	65 - 79 dB(A)		

Dimensions



	mm	inch
A =	347	13.66
B =	255	10.04
C =	40	1.58

B_02165